

Dynascaler

Air-Powered Descaling and Surface Preparation Tool

For Heavy-Duty Industrial, Marine, Construction Applications

FOR "BONDED SHOT"
FLAP ACCESSORIES
SEE PAGE 293

- All models use optional "bonded shot" flap assemblies.
- Ideal for weld preparation, plus removing rust, oxide, scale, old paint and tough coatings.

Hand-Held Models

- Steel dowel pin (keepers) system allows easy flap loading and unloading.
- Four-position top handle adjusts for operator comfort.

Model 30304 *Straight Line*

- For 2" wide work on inside of pipe.
- Six-slot hub (2-1/4" wide) accepts optional "bonded shot" flap assemblies. Adjustable for exact positioning of flap assemblies to surface.

Model 30336 *Straight Line*

Model 30337 *Right Angle*

- Each model is for 2" wide work on flat surfaces.
- Ideal for removal of floor paint/coatings and for scarifying concrete.
- Vacuum port accepts 1-1/2" diameter cuff.
- Model 30337 is USA Government National Stock Number 389501149337.



Model 30304



Model 30336

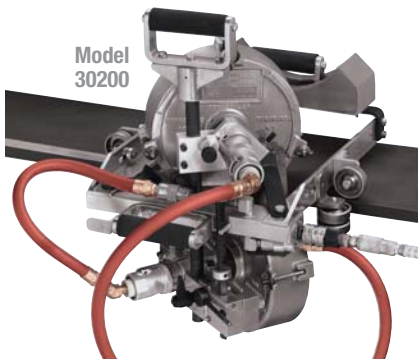

Model 30200

Over-Under Model

Model 30200 *1" Wide Top and Bottom*

- Mechanically fractures scale and coatings, with negligible removal of base metal.
- "Over-under" simultaneous removal of scale, from top and bottom of girder webplates prior to welding.
- Top and bottom unit each use optional 1" wide "bonded shot" flap assemblies. Top unit easily detaches to permit portable "touch up" descaling.

Floor Models

Model 30303 *2" Wide*

Model 31600 *3" Wide*

- Each model has 20-slot hub for optional "bonded shot" flap assemblies.
- Adjustable edge guide assures straight-line descaling. (Not recommended for use without edge guide.)

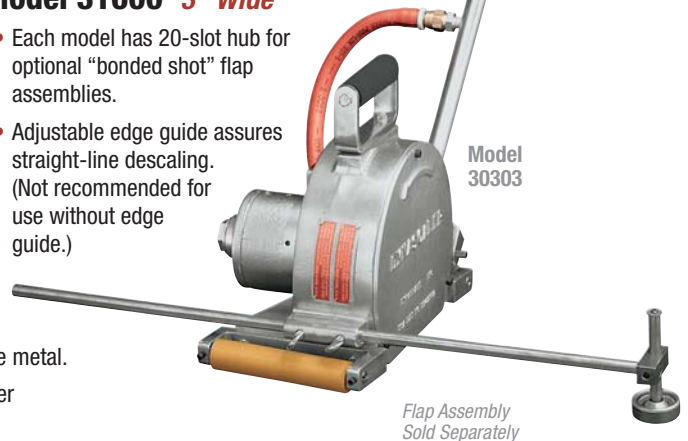

Model 30303

Flap Assembly Sold Separately

Model Number	Motor hp (W)	RPM Free Speed	RPM Under Load	Sound Level	Maximum Air Flow SCFM (L/Min)	Hose I.D. Size Inch (mm)	Spindle Thread	Weight Pound (kg)	Length Inch (mm)	Height Inch (mm)
30303	1.7 (1,268)	3,000	1,650	94 dB(A)	78 (2,209)	1/2 (13)	–	44.2 (20)	8-3/4 (222)	11 (279)
31600	4.0 (2,983)	3,000	1,650	94 dB(A)	127 (3,597)	1/2 (13)	–	54 (24.5)	8-3/4 (222)	11 (279)
30200	.7 (522)	3,400	2,100	94 dB(A)	38 (1,076)	1/2 (13)	–	33.2 (15)	14 (355)	10-3/4 (273)
30304	.7 (522)	3,400	2,400	92 dB(A)	38 (1,076)	1/2 (13)	1/2"-20 Male	6.2 (2.8)	11-3/4 (298)	8-1/4 (210)
30336	.7 (522)	3,400	2,400	92 dB(A)	38 (1,076)	1/2 (13)	1/2"-20 Male	6.5 (2.9)	11-3/4 (298)	8-1/4 (210)
30337	.7 (522)	3,100	1,950	94 dB(A)	38 (1,076)	1/2 (13)	1/2"-20 Male	6.5 (2.9)	11-3/4 (298)	8-1/4 (210)

Tune-Up Kit: No. 96260 (page 267) • Additional Specifications: Air Pressure 90 PSIG (6.2 Bar), Air Inlet Thread 3/8" NPT