

# Bench & Pedestal Belt Grinders

Versatile Two-Wheel Belt Grinding Machine for Heavy Duty Use

*Powers Abrasive Belts 2-1/2" wide by 60" long (64 mm x 1,524 mm)*

**FOR ABRASIVE BELTS**  
2-1/2" wide x 60" long  
(64 mm x 1,524 mm)  
**NOT INCLUDED**

*NEW Dynabrade Bench & Pedestal Belt Grinder is ideal for heavy duty grinding applications, working from the contact wheel or platen pad. Machine design allows rotation of housing from vertical to horizontal positions, for optimum grinding efficiency. Offered in complete range of electrical configurations (see chart below).*



## Models 67800 – 67813

- Grind from contact wheel or platen; ideal for countless heavy duty applications.
- Fully guarded to meet all OSHA standards.
- Work rest is adjustable to ensure accurate bevel grinding.
- Quick and easy belt change minimizes downtime and increases efficiency.
- Can be bench-mounted or attached to optional 67500 adjustable Pedestal Stand, as shown.
- Optional 67966 Vacuum Scoop also available, for efficient capture of dust and debris.

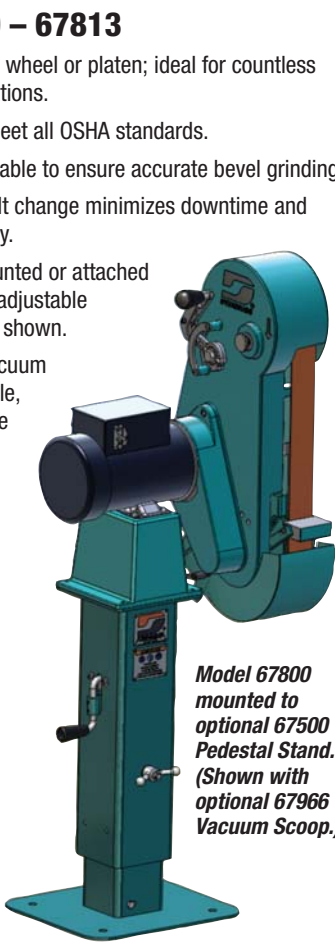

*Model 67800 mounted to optional 67500 Pedestal Stand. (Shown with optional 67966 Vacuum Scoop.)*

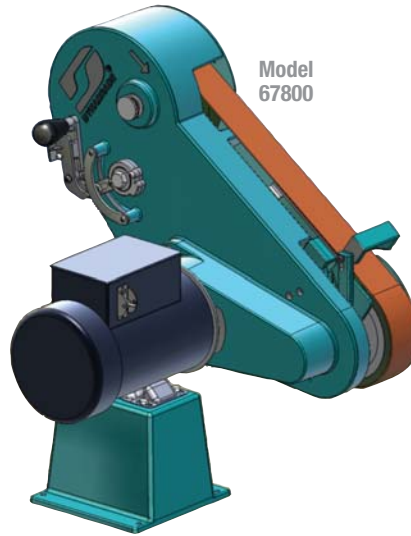

Model 67800

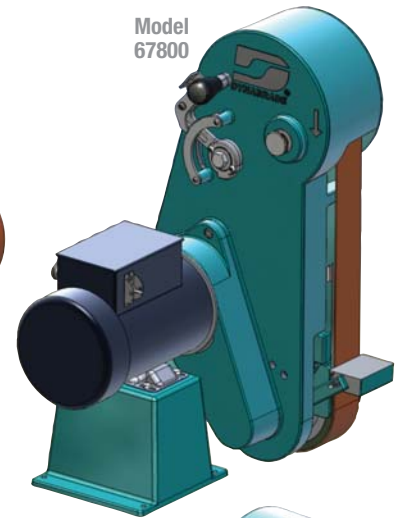

Model 67800

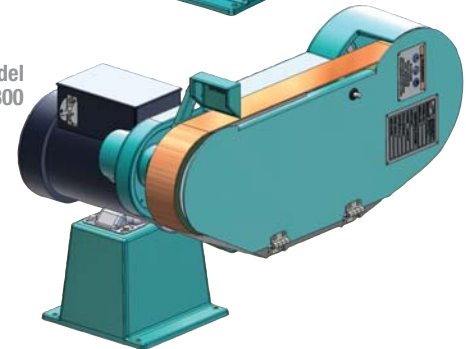

Model 67800

Model Number	Motor hp (W)	Full Load Amperage	Voltage/Phase/Frequency	SFPM (SM/Min)	Sound Level	Weight Pound (kg)	Height Inch (mm)	Width Inch (mm)	Length Inch (mm)
67800	1.5 (1,119)	12.1	115 / 1 / 60	8,000 (2,438)	85 dB(A)	110 (50)	29 (737)	21 (533)	29 (737)
67801	1.5 (1,119)	6	230 / 1 / 60	8,000 (2,438)	85 dB(A)	110 (50)	29 (737)	21 (533)	29 (737)
67802	1.5 (1,119)	4.6	230 / 3 / 60	8,000 (2,438)	85 dB(A)	110 (50)	29 (737)	21 (533)	29 (737)
67803	1.5 (1,119)	2.3	460 / 3 / 60	8,000 (2,438)	85 dB(A)	110 (50)	29 (737)	21 (533)	29 (737)
67804	3 (2,238)	3	230 / 3 / 60	8,000 (2,438)	85 dB(A)	120 (54)	29 (737)	22 (559)	29 (737)
67805	3 (2,238)	3	460 / 3 / 60	8,000 (2,438)	85 dB(A)	120 (54)	29 (737)	22 (559)	29 (737)
67806	1.5 (1,119)	15.2	115 / 1 / 60	4,000 (1,219)	85 dB(A)	110 (50)	29 (737)	21 (533)	29 (737)
67807	1.5 (1,119)	7.6	230 / 1 / 60	4,000 (1,219)	85 dB(A)	110 (50)	29 (737)	21 (533)	29 (737)
67808	1.5 (1,119)	4.8	230 / 3 / 60	4,000 (1,219)	85 dB(A)	110 (50)	29 (737)	21 (533)	29 (737)
67809	1.5 (1,119)	2.4	460 / 3 / 60	4,000 (1,219)	85 dB(A)	110 (50)	29 (737)	21 (533)	29 (737)
67810	3 (2,238)	8.6	230 / 3 / 60	4,000 (1,219)	85 dB(A)	120 (54)	29 (737)	22 (559)	29 (737)
67811	3 (2,238)	4.3	460 / 3 / 60	4,000 (1,219)	85 dB(A)	120 (54)	29 (737)	22 (559)	29 (737)
67812	1.5 (1,119)	20	115 / 1 / 60	800-8,000 (244-2,438)	85 dB(A)	110 (50)	29 (737)	21 (533)	29 (737)
67813	1.5 (1,119)	10	230 / 1 / 60	800-8,000 (244-2,438)	85 dB(A)	110 (50)	29 (737)	21 (533)	29 (737)