

Bench & Pedestal Disc Grinders

Versatile Disc Grinding Machine for Countless Applications

Powers Abrasive Discs 12" (305 mm) in Diameter

FOR ABRASIVE DISCS
12" (305 mm) diameter
NOT INCLUDED

NEW Dynabrade Bench & Pedestal Disc Grinder is ideal for a variety of applications, including grinding and deburring castings or fabricated parts. Also used for shaping, flat grinding and contouring on metal, wood and plastic. Machine design allows quick disc change, and easy adjustment of work table for optimum efficiency. Offered in complete range of electrical configurations (see chart below).

Models 67600 – 67605

- Adjustable work table with miter ensures accurate angle grinding.
- Runs in forward and reverse modes.
- Fully guarded with adjustable work rest to meet all OSHA standards.
- Quick and easy disc change minimizes downtime and increases efficiency.
- Can be bench-mounted or attached to optional 67500 adjustable Pedestal Stand, as shown.

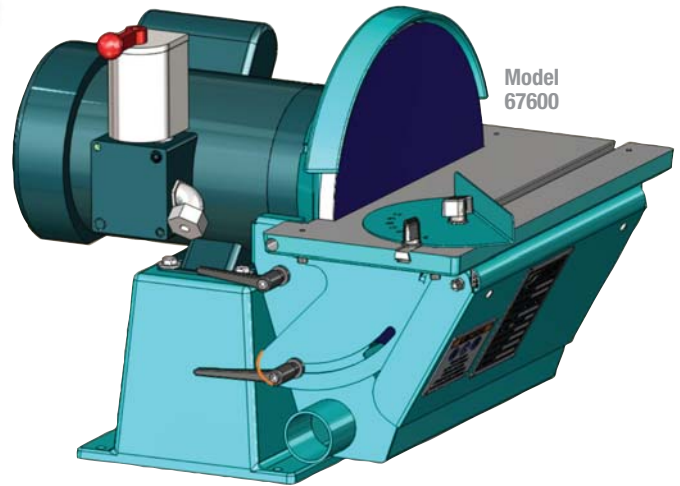

Model 67600

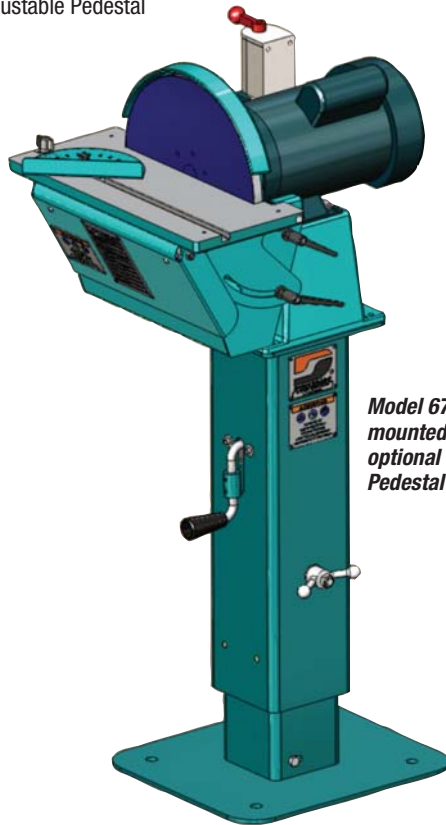

Model 67600
mounted to
optional 67500
Pedestal Stand

67500 Pedestal Stand For All Bench & Pedestal Models

- Quick and easy height adjustment, from 28" to 38" high.
- Rigid assembly with capacity up to 300 pounds.
- 1/4" steel tool mount plate and pedestal base.

Model Number	Motor hp (W)	Full Load Amperage	Voltage/Phase/Frequency	RPM	Sound Level	Weight Pound (kg)	Height Inch (mm)	Width Inch (mm)	Length Inch (mm)
67600	1 (746)	13.4	115 / 1 / 60	1,725	70 dB(A)	90 (41)	17 (432)	21 (533)	18 (457)
67601	1 (746)	6.7	230 / 1 / 60	1,725	70 dB(A)	90 (41)	17 (432)	21 (533)	18 (457)
67602	1.5 (1,119)	20	115 / 1 / 60	500-1,725	70 dB(A)	90 (41)	17 (432)	21 (533)	18 (457)
67603	1.5 (1,119)	10	230 / 1 / 60	500-1,725	70 dB(A)	90 (41)	17 (432)	21 (533)	18 (457)
67604	1.5 (1,119)	6.9	230 / 3 / 60	500-1,725	70 dB(A)	90 (41)	17 (432)	21 (533)	18 (457)
67605	1.5 (1,119)	3.6	460 / 3 / 60	500-1,725	70 dB(A)	90 (41)	17 (432)	21 (533)	18 (457)