

# .4 hp Die Grinders

## Right Angle and 7° Offset Models

See Our Features and Benefits: Discover The Dynabrade Difference!

Available in speeds of 3,200 RPM, 5,000 RPM, 12,000 RPM, 15,000 RPM, 20,000 RPM, 25,000 RPM and 30,000 RPM.

Tools include Kevlar® phenolic vanes for longer life.

Registered trademark of DuPont de Nemours, El, & Co., Inc.

See all models on pages 57-58!



Features dual wick lubrication system, saturated with gear oil for extended gear life (over 700 hours with proper use of gear oil), increased performance and reduced downtime.

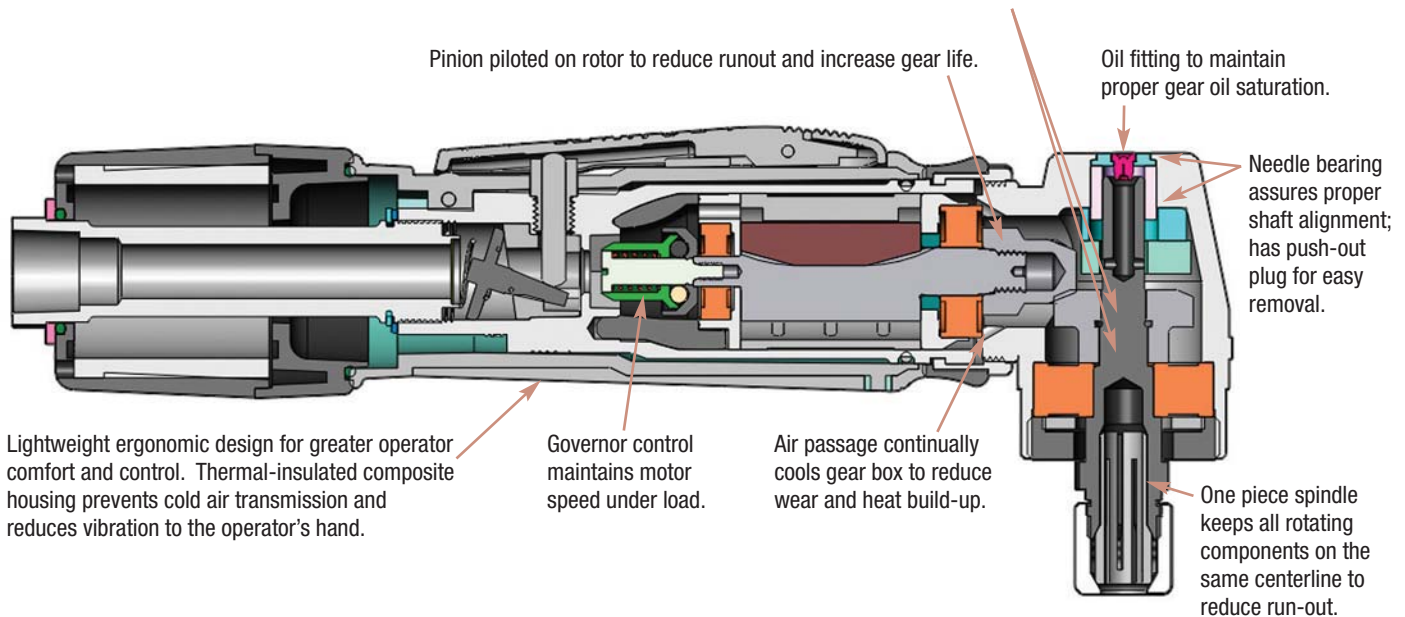

### Features and Advantages

- Kevlar® phenolic vanes for longer life.
- Lightweight ergonomic design for greater comfort and control.
- One-piece spindle keeps all rotating components on the same centerline for reduced run-out, which means lower vibration levels for enhanced operator comfort.
- Front and rear exhaust models. Air passage to continually cool the gear box – gears last longer!
- Pinion piloted on rotor to reduce run-out.
- Needle bearing assures proper shaft alignment.
- Dual wick lubrication system – saturated with gear oil for extended gear life – over 700 hours. This helps administer the right amount and keep the gear oil on the metal gears.
- Highest horsepower and torque levels of any similar competitive product.

### Benefits

- Increased performance from higher torque levels. You can really “work” these tools. Stall out torque is the highest in the marketplace.
- We use **Gear Oil** as opposed to grease. **Gear Oil** is *specifically formulated to STICK TO METAL*. Grease does not stick and the centrifugal force of the spinning gears throws the grease away from the metal surface.
- Longer gear life means reduced downtime and less costly repairs.
- Front and rear exhaust models – user can decide which configuration is right for them. More choice means more control of their purchase.
- Insulated housings provide “warm tools” for the users and helps prevent worker’s injuries like “white finger”.
- Lower vibration levels help prevent worker injuries such as Carpal Tunnel Syndrome. Machines are easier to use because they do not “buzz” in your hands. Workers can use smooth running machines longer.
- Low profile machines are ideal for “hard-to-reach” areas. A performance plus!
- All machines are perfectly compatible with all Dynabrade Accessories. Providing systemized solutions for our customers is a key to Dynabrade’s success.