

Models:

- 57220 - 5" Non-Vacuum
- 57221 - 5" Vac-Ready
- 57222 - 5" Basic Vac
- 57223 - 5" Deluxe Vac
- 57224 - 5" Central Vac-Ready
- 57225 - 6" Non-Vacuum
- 57226 - 6" Vac-Ready
- 57227 - 6" Basic Vac
- 57228 - 6" Deluxe Vac
- 57229 - 6" Central Vac-Ready

For Serial No. 0A1000 and Higher

Parts Page Reorder No. PD00•78
Effective October, 2000
Supersedes PD00•09

Dynalocke™ Dual Action Sander

Air Motor and Machine Parts

WARNING

Always operate, inspect and maintain this tool in accordance with the Safety Code for portable air tools (ANSI B186.1) and any other applicable safety codes and regulations. Please refer to Dynabrade's Warning/Safety Operating Instructions for more complete safety information. See inside for Important Operating, Maintenance and Safety Instructions.

Index Key

No. Part # Description

- | | |
|-------|---------------------------------|
| 1 | Sanding Pads |
| 56104 | 5" Vacuum |
| 56105 | 6" Vacuum |
| 56106 | 5" Non-Vacuum |
| 56107 | 6" Non-Vacuum |
| 2 | 95858 Shim |
| 3 | 95859 Shim |
| 4 | 57369 Shroud |
| 5 | 57262 Balancer Shaft |
| 6 | 95630 Snap Ring |
| 7 | 95628 Bearing Shield |
| 8 | 56053 Bearing Seal |
| 9 | 56052 Balancer Bearing |
| 10 | Motor Shaft Balancer |
| 57268 | - 5" |
| 57269 | - 6" |
| 11 | 54673 Rotor Key |
| 12 | 96166 Set Screw |
| 13 | 57332 Lock Ring |
| 14 | 02695 Bearing |
| 15 | 54630 Front Plate |
| 16 | 54705 Rotor/Blade Set |
| 17 | 54631 Cylinder Assy. |
| 18 | 95865 Line-Up Pin |
| 19 | 54629 Rear Plate |
| 20 | 01206 Bearing |
| 21 | 56713 Lock Assy. |
| 22 | 56712 Switch (Bottom) |
| 23 | Housing |
| 57230 | 5" Non-Vac |
| 57231 | 5" Vac-Ready |
| 57232 | 5" Central Vac |
| 57237 | 6" Non-Vac |
| 57238 | 6" Vac Ready |
| 57239 | 6" Central Vac |
| 24 | 96252 Spring |
| 25 | 56705 Post - Cap |
| 26 | 57264 Post Assembly |
| 27 | 96065 O-Ring |
| 28 | 56711 Switch (Top) |
| 29 | 96489 Screw |
| 30 | 95523 O-Ring (2) |
| 31 | 57382 Gasket (Non-Vac) |
| | 57383 Gasket (Vac) |
| 32 | 56671 Handle |
| 33 | 96123 Screw (2) |
| 34 | 57375 Valve Stem |
| 35 | 95886 Flat-Washer (4) |
| 36 | 01211 Lock Washer (6) |
| 37 | 97010 Screw (4) |
| 38 | 01464 Seal (2) |
| 39 | 01472 Tip Valve |
| 40 | 01468 Conical Spring |
| 41 | 56673 Gasket |
| 42 | 96328 O-Ring |
| 43 | 98597 Retaining Ring |
| 44 | 01089 Safety Lever |
| 45 | 01017 Pin |
| 46 | 56672 Adapter |
| 47 | 01024 O-Ring (2) |
| 48 | 57343 Speed Regulator |
| 49 | 96421 Flat-Washer (2) |
| 50 | 01788 Screw (2) |
| 51 | 01494 Inlet Bushing |
| 52 | 54199 Muffler Seat (Non-Vacuum) |
| 53 | 54195 Muffler (3) (Non-Vacuum) |
| 54 | 54194 Muffler Cap (Non-Vacuum) |

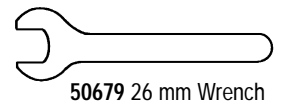
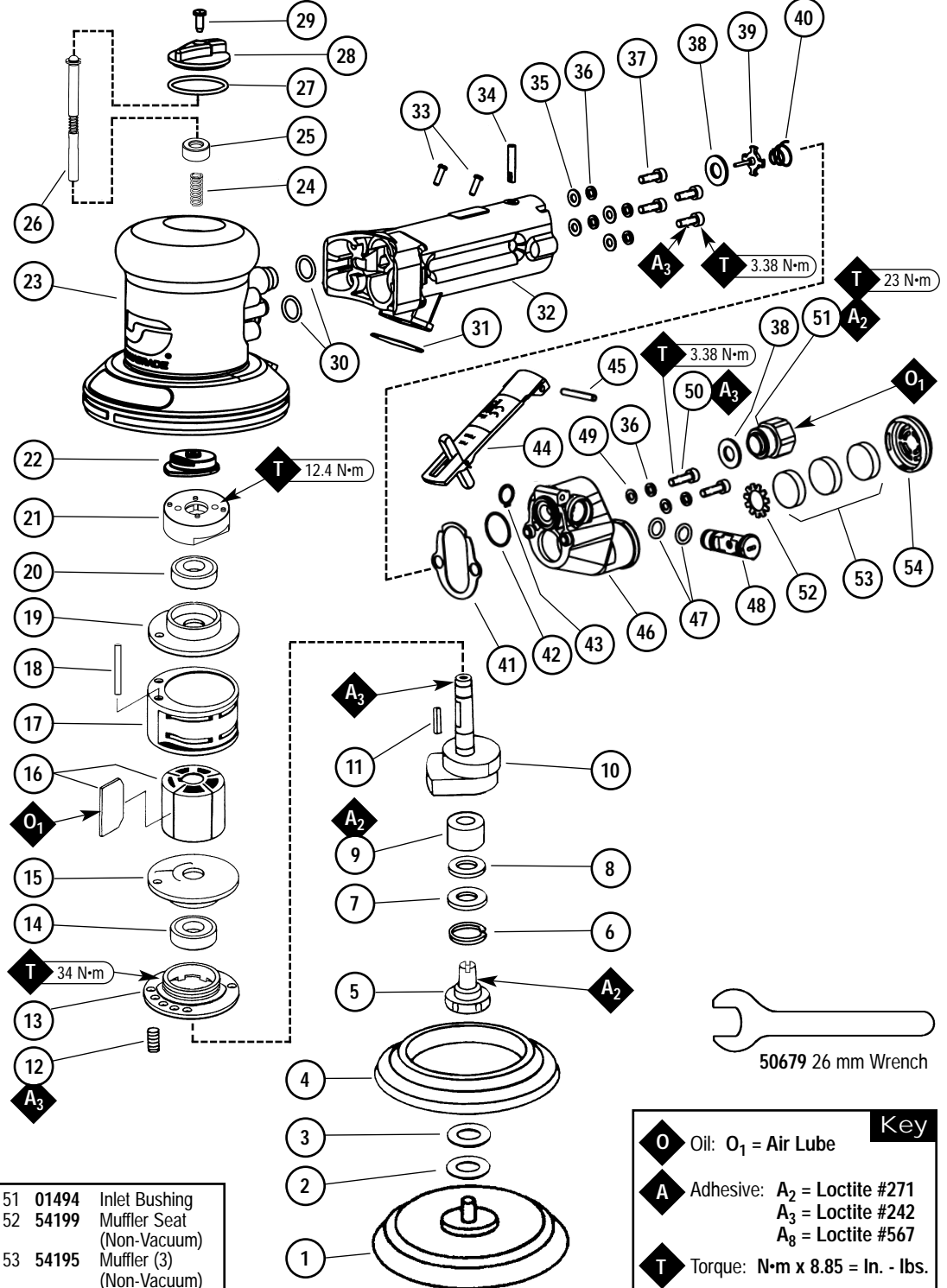

| | | |
|----------|---|------------|
| O | Oil: O ₁ = Air Lube | Key |
| A | Adhesive: A ₂ = Loctite #271 A ₃ = Loctite #242 A ₈ = Loctite #567 | |
| T | Torque: N·m x 8.85 = In. - lbs. | |

Note: To order replacement parts specify the Model# and Serial# of your machine.

Important Operating, Maintenance and Safety Instructions

Carefully read all instructions before operating or servicing any Dynabrade® Abrasive Power Tool.

Warning: Hand, wrist and arm injury may result from repetitive work motion and overexposure to vibration.

Important: All Dynabrade Rotary Vane air tools must be used with a filter-regulator-lubricator to maintain all warranties.

Operating Instructions:

Warning: Eye, face, respiratory, sound and body protection must be worn while operating power tools. Failure to do so may result in serious injury or death
Follow safety procedures posted in workplace.

1. With power source disconnected from tool, securely fasten abrasive/sanding pad on tool.
2. Connect power source to tool. Be careful **not** to depress throttle lever in the process.
3. Check tool speed with tachometer. If tool is operating at a higher speed than the RPM marked on the tool or operating improperly, the tool should be serviced to correct the cause before use.
4. To avoid the danger of contaminating the workpiece from the lubricating oils permeating the air or sanding dust, it is recommended that this machine be hooked up to a central vacuum system or one of our unique vacuum systems that gather all such contaminants in a paper or cloth dust bag. This self contained vacuum system is highly efficient and convenient to use since it does not need to be attached to a separate vacuum system and is as mobile as the machine itself.

Maintenance Instructions:

1. All Dynabrade Rotary Vane air motors should be lubricated. Dynabrade recommends one drop of air lube per minute for each 10 SCFM (example: if the tool specifications state 40 SCFM, set the drip rate of your filter-lubricator at 4 drops per minute). Dynabrade Air Lube (P/N 95842: 1 pt. 473 ml.) is recommended.
2. An Air Line Filter-Regulator-Lubricator must be used with this air tool to maintain all warranties. Dynabrade recommends the following: 11405 Air Line Filter-Regulator-Lubricator — Provides accurate air pressure regulation, two-stage filtration of water contaminants and positive-drip lubrication of pneumatic components. Operates up to 40 SCFM @ 100 PSIG has 3/8" NPT female ports.
3. Frequent drainage of water traps in air lines is recommended.
4. Some silencers on air tools may clog with use. Clean and replace as required.
5. A Motor Tune-Up Kit (P/N 96122) is available which includes assorted parts to help maintain and refresh motor.

Safety Instructions:

Products offered by Dynabrade should not be converted or otherwise altered from original design without expressed written consent from Dynabrade, Inc.



- **Important:** User of tool is responsible for following accepted safety codes such as those published by the American National Standards Institute.
- Tool RPM must never exceed abrasive/sanding pad RPM rating, regardless of tool capacity.
- Operate machine for 30 seconds before application to workpiece to determine if machine is working properly and safely before work begins.
- Always disconnect power supply before changing abrasive or making machine adjustments.
- Inspect abrasives and sanding pads for damage or defects prior to and during operation of tool.
- Please refer to Dynabrade's Warning/Safety Operating Instructions Tag (Reorder No. 95903) for more complete safety information.
- **Warning:** Hand, wrist and arm injury may result from repetitive work, motion and overexposure to vibration.

Notice

All Dynabrade motors use the highest quality parts and metals available and are machined to exacting tolerances. The failure of quality pneumatic motors can most often be traced to an unclean air supply or the lack of lubrication. Air pressure easily forces dirt or water contained in the air supply into motor bearings causing early failure. It often scores the cylinder walls and the rotor blades resulting in limited efficiency and power. Our warranty obligation is contingent upon proper use of our tools and cannot apply to equipment which has been subjected to misuse such as unclean air, wet air or a lack of lubrication during the use of this tool.

Note: To order replacement parts specify the model and serial number of your machine.

Full One Year Warranty

Following the reasonable assumption that any inherent defect which might prevail in a product will become apparent to the user within one year from the date of purchase, all equipment of our manufacture is warranted against defects in workmanship and materials under normal use and service. We shall repair or replace at our factory, any equipment or part thereof which shall, within one year after delivery to the original purchaser, indicate upon our examination to have been defective. Our obligation is contingent upon proper use of Dynabrade tools in accordance with factory recommendations, instructions and safety practices. It shall not apply to equipment which has been subject to misuse, negligence, accident or tampering in any way so as to affect its normal performance. Normally wearable parts such as bearings, contact wheels, rotor blades, etc., are not covered under this warranty.

| Machine Number | Length Inch (mm) | Height Inch (mm) | Weight Pound (kg) | Motor RPM | Air Flow Rate SCFM (LPM) | Sound Level | Motor HP (W) |
|----------------|------------------|------------------|-------------------|-----------|--------------------------|-------------|--------------|
| 5" Models | 10-1/4" (260) | 5" (127) | 2.8 lbs (1.27) | 12,000 | 25 (708) | 82 dBA | .4 (298) |
| 6" Models | 10-1/4" (260) | 5" (127) | 2.9 lbs (1.31) | 12,000 | 25 (708) | 82 dBA | .4 (298) |

Additional Specifications: Air Inlet Thread 1/4" NPT • Hose I.D. Size 3/8" (10 mm) • 90 PSIG (6.2 Bars)

Motor Assembly/Disassembly Instructions

Important: Manufacturers warranty is void if tool is disassembled before warranty expires.

These instructions are for use in conjunction with Part Number 57260 Repair Kit, which includes special tools for proper disassembly/assembly of tool. A complete tune-up kit, part number 96122, is available which includes assorted parts to help maintain and repair motor.

To Disassemble:

1. Invert machine and secure in vice, using 57092 Collar (supplied in 57260 Repair Kit) or padded jaws.
2. Remove sanding pad with 50679 Open-end Wrench (supplied with sander).
3. Using a 2 mm hex key remove the 96166 Set Screw.
4. Insert 56058 Lock Ring Wrench (supplied in 57260 Repair Kit) into corresponding tabs of lock ring and unscrew. Motor may now be lifted out for service.
5. a.) Remove 57264 Post, 56705 Post Cap, and 96252 Spring From top of motor. These parts should freely fall from Motor Assembly. Upper motor can now be disabled.
b.) Using a 26 mm wrench, unscrew (left handed thread) 56713 Lock Assembly from 57268 or 57269 Motor Shaft Balancer.
6. Using a small #2 arbor press remove the rear plate assembly by securing the 54631 Cylinder in a standard 2 inch bearing separator or use a standard bearing puller gripped on the cylinder inlet/exhaust area. Push the motor shaft balancer through the bearing. Remove cylinder, rotor, vanes and key.
7. Remove 54630 Front Plate and 02695 Front Motor Bearing, using a standard 2 inch Bearing Separator.
8. Disassemble the balancer assembly as follows:
 - a.) Remove 95630 Snap ring. Screw the threaded portion of the 56056 Bearing Puller (supplied in 57260 Repair Kit) into the 57262 Balancer Shaft.
Note: Heat the outside of the motor shaft balancer to approximately 200° F. Now, using the slider weight, pull the assembly out.
 - b.) Press off 56052 Bearing and remove loose parts.
9. If during step 8, the 56052 Bearing remains in the motor shaft balancer, it can be removed by the heating the shaft balancer again and using either an inside bearing puller or a blind hole bearing puller.

To Reassemble:

Important: Be certain parts are clean and in good repair before reassembling.

1. Assemble the balancer assembly as follows:
 - a.) Install 95630 Snap Ring onto 57262 Balancer Shaft. Install 95628 Shield with convex face toward hex of balancer shaft.
 - b.) Install 56053 Bearing Seal. **Note:** Be certain seal is pressed completely over shaft step.
 - c.) Apply a slight amount of #271 Loctite® (or equivalent) to inside diameter of the 56052 Bearing and the outside diameter of the 57262 Balancer Shaft.
 - d.) Press fit 56052 Bearing, with seal side toward hex of balancer shaft, up to shaft step using 57091 Bearing Press Tool (supplied in 57260 Repair Kit) (Drawing 1).
2. Place the motor shaft balancer in a soft jaw vise with large end-up.
3. Apply a slight amount of #271 Loctite® (or equivalent) and spread over several places around the outside diameter of the 56052 Bearing and slide balancer shaft assembly into the motor shaft balancer until 56052 Bearing is firmly seated at bottom. Squeeze 95630 Snap Ring into groove in motor shaft balancer to complete the assembly. Remove from vise.
4. Press 02695 Bearing onto the motor shaft balancer down to the shoulder using 57091 Bearing Press Tool (Drawing 2).
5. Place 57332 Lock Ring onto shaft with lock ring assembly facing balancer shaft assembly.
6. Place 54630 Front Bearing Plate onto 02695 Bearing and check for smooth rotation (Drawing 3).
7. Place 54673 Rotor Key, 54705 Rotor, and Blade set onto shaft. **Note:** Be certain rotor “floats” easily on the shaft. Because the design of this motor uses a “floating rotor”, There is no need to set or adjust gap between the rotor and the end plates.
8. Place 54631 Cylinder over rotor. The “short” line-up pin goes toward the 54630 Front Bearing Plate.
9. Place 54629 Rear Bearing Plate and 01206 Rear Bearing over shaft and “long” end of line-up pin and press into place (Drawing 4).
10. a.) Clean exterior threads on 57268 or 57269 Motor Shaft Balancer and apply a slight amount of #271 Loctite® or equivalent.
b.) Tighten 56713 Lock Assembly onto 57268 or 57269 Shaft Balancer to 12.4 N-m.
c.) Drop 96252 Spring, 56705 Post Cap, and 57264 Post Assembly in thru hole of shaft balancer.

Drawing 1

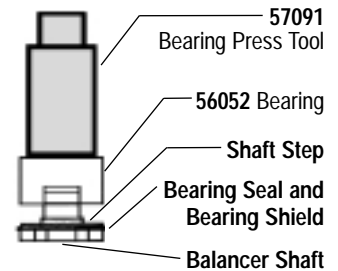

(continued on next page)

Drawing 2

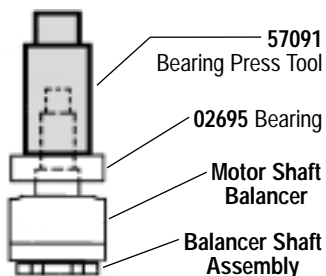

Drawing 3

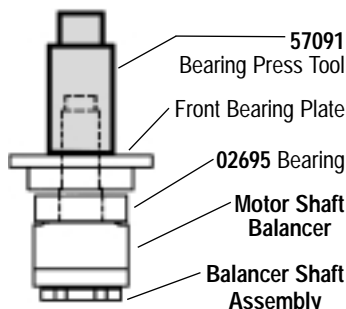

Drawing 4

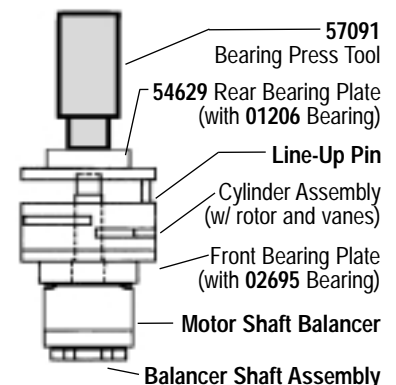

Motor Disassembly/Assembly Instructions (continued)

- Grease the rubber seals inside the housing using a small amount of multipurpose grease or petroleum jelly.
Note: Be certain that rubber seals in housing have not pulled out of their seat during disassembly. If this has happened re-seat seals by pushing them until they are flush with inside diameter.
- Slide motor assembly into housing. **Note:** With handle pointing down be certain line-up pin enters slot to the right of center.
- Secure motor housing in a vise, using **57092** Collar or soft jaws (be careful not to over tighten tool in vise).
- Pull up on counter balance so that approximately 1/4" of the motor is visible above the threads of the housing. Slip **57332** Lock Ring over counter balance and push down lock ring with **56058** Lock Ring Wrench turning it clockwise to tighten lock ring in place. Torque: (34 N·m/300 in. - lbs.)
- Apply a small amount of #242 Loctite (or equivalent) to threads of **96166** Set Screw. Use a 2 mm hex key and install set screw into the housing through one of the holes in the lock ring until set screw is flush with the top of the lock ring.

To Disassemble Valve And Speed Regulator Assemblies:

- Invert tool and place in soft jaw vise or use **57092** Repair Collar.
- Loosen and remove **01788** Screws (2), **01211** Lock Washers (2) and **96421** Flat Washers (2) from **56672** Adapter.
- Carefully remove **56672** Adapter making sure no parts fall to the ground. On non-vacuum models: pry off **54194** Muffler Cap and remove **54195** Muffler (3).
- Remove **57343** Speed Regulator by detaching **98597** Retaining Ring with a pair of retaining ring pliers. Remove **01024** O-Rings with a small screwdriver.
- Remove tip valve, valve seal and valve stem from housing.

To Reassemble Valve And Speed Regulator Assemblies:

- Lightly lubricate **01024** O-Rings and slide them on **57343** Speed Regulator. Install through regulator hole on **56672** Adapter. Place **98597** Retaining Ring on groove of speed regulator using a pair of retaining ring pliers.
- Line-up hole in valve stem with inlet hole in handle. Place **01464** Seal in handle. Insert **01472** Tip Valve so that metal pin goes through the valve stem. Place **01468** Spring into the housing, small end first.
- Install **98597** O-Ring onto **56672** Adapter and place **56673** Gasket onto handle.
- Gently line-up **56672** Adapter onto handle so no parts shift when tightening. Apply #242 Loctite to **01788** Screws (2), install along with **01211** Lock Washers (2) and **96421** Flat Washers (2).

Motor assembly is complete. Please allow 30 minutes for adhesives to cure before operating tool.

Important: Motor should operate at 12,000 RPM at 6.2 bar (90 PSIG). RPM should be checked with a tachometer. Before operating, we recommend that 3-4 drops of pneumatic tool oil be placed directly into the air inlet with throttle lever depressed. Operate tool for 30 seconds to determine if machine is operating properly and to allow lubricating oils to properly dispense through machine.

To Change Disc Pads:

Insert **50679** Wrench on flats of **57262** Balancer Shaft. Twist off sanding pad by hand. With wrench still in place, hand tighten new pad on tool. No need to remove shroud or overskirt.

Required Weight of Pads:

- 5" Models – Use pad weighing 100g.
- 6" Models – Use pad weighing 130g.

Loctite® is a registered trademark of the Loctite Corp.

Accessories



54290 "Bag-in-Box" System

- 95361** Air Line 5' long.
- 50682** Flex-Hose 1" dia. x 6' long.
- 95362** Rubber Connectors (5).
- 95575** Durable Box Receptacle.
- Sample paper bag included.
Paper bag reorder:
50692 (400/case) or
50693 (24 per package.)



50617, 56303 – 6' Long Flex-Hose Systems

- 50617:** Has **50683** Standard Reusable Cloth Bag with hook 'n loop end for easy emptying.
- 56303:** Has **56304** Zipper-Lock Bag.
- Both systems include 6' long **50682** Flex-Hose.
- Shown with optional **95361** Air Line (1/4").



57260 Motor Repair Kit:

- Contains special tools for Disassembly/Assembly of machine.

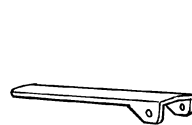

57344 Throttle Lever

- A **57396** Valve Stem must be used in conjunction with this lever to function properly.



96122 Motor Tune-Up Kit:

- Includes assorted parts to help maintain and repair motor.



Visit our Web Site: www.dynabrade.com

Email: Customer.Service@Dynabrade.com

DYNABRADE, INC., 8989 Sheridan Drive • Clarence, NY 14031-1490 • Phone: (716) 631-0100 • Fax: 716-631-2073 • International Fax: 716-631-2524
DYNABRADE EUROPE S.à.r.l., Zone Artisanale • L-5485 Wormeldange—Haut, Luxembourg • Telephone: 352 76 84 94 1 • Fax: 352 76 84 95 1

©DYNABRADE, INC., 2000

PRINTED IN USA