

Models:

- 51370 - 4" Roloc® Disc Sander**
- 51371 - 4-1/2" Disc Sander**
- 52620 - 5" Depressed Center Wheel Grinder (5/8" x 11)**
- 52625 - 5" Depressed Center Wheel Grinder (M14 x 2)**

1.3 Horsepower Tools

Air Motor and Machine Parts

⚠ WARNING

Always operate, inspect and maintain this tool in accordance with the Safety Code for portable air tools (ANSI B186.1) and any other applicable safety codes and regulations. Please refer to Dynabrade's Warning/Safety Operating Instructions for more complete safety information.

KEY

- O** Oil: O₁ = Air Lube
- A** Adhesive: A₁ = Loctite #609
A₈ = Loctite #567
A₁₀ = Loctite #243
- T** Torque: N•m x 8.85 = In. - lbs.

Index Key

No. Part # Description

1	Lock Flange	
	53696	5/8" x 11
	53631	M14 x 2
2	Flange	
	53697	5/8" x 11
	53630	M14 x 2
3	54979	Guard
4	50192	4" Pad
5	94592	Spring
6	54896	Pin
7	54895	Button
8	96513	Shaft
9	54978	Lock Ring
10	54975	Rotor Nut
11	02552	Bearing
12	54899	Shim
13	54889	Shim
14	01277	Shim Pack (3/pkg.)
15	54974	Front Bearing Plate
16	52467	Rotor Spacer
17	Rotor	
	54971	Disc Sander
	54965	DCWG - 5/8"-11
	54632	DCWG - M14 x 2
	54080	Roloc® Sander
18	54972	Rotor Vane 5/Pkg.
19	54976	Cylinder (Incl. 51046 Pin)
20	51046	Pin
21	54977	Rear Bearing Plate
22	02651	Bearing
23	52609	Housing
24	96328	O-Ring
25	54803	Shim
26	54093	Lock Nut
27	54969	Rear Exhaust Insert
28	54897	Spring
29	54970	Plunger
30	03029	O-Ring
31	53209	Side Handle
32	51949	Safety Lock Lever
33	96444	Pin
34	Housing (Includes Labels)	
	54926	Model - 51370
	54925	Model - 51371
	54924	Model - 52620
	54927	Model - 52625
35	51946	Valve Stem Assembly (Incl. 96443 O-Ring)
36	51945	Seat
37	51944	Tip Valve
38	51943	Spring
39	96442	O-Ring
40	51940	Retainer
41	51939	Air Diffuser
42	51937	Inlet Adapter

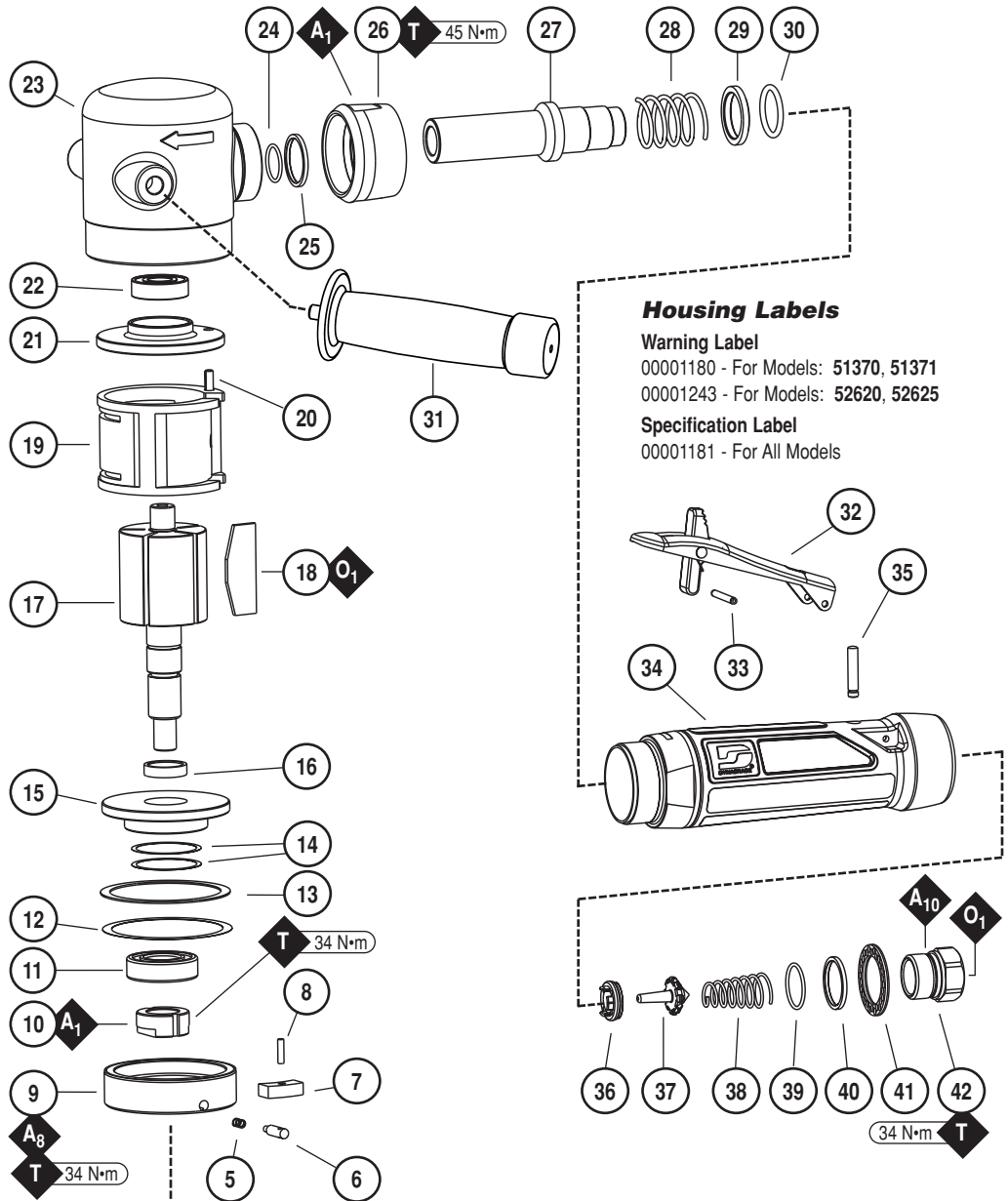

Housing Labels

Warning Label

00001180 - For Models: 51370, 51371
00001243 - For Models: 52620, 52625

Specification Label

00001181 - For All Models

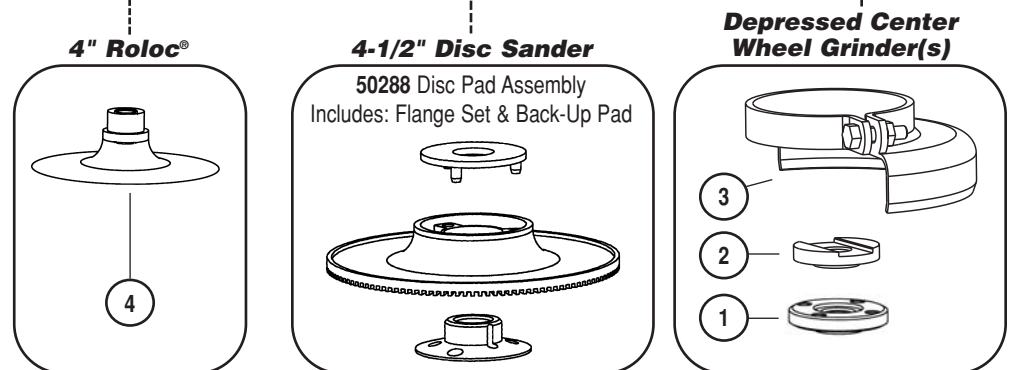
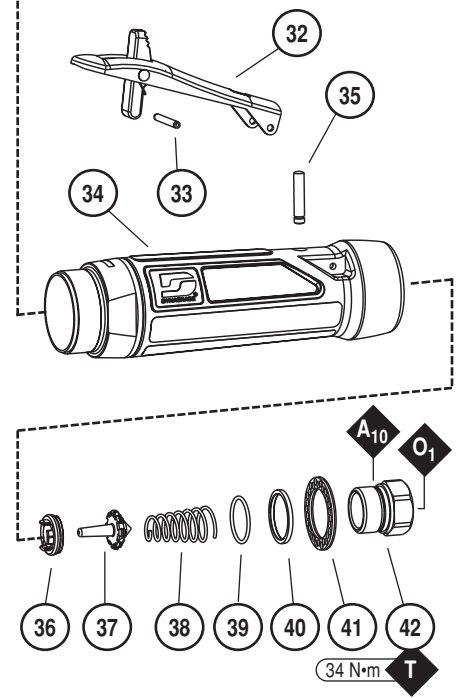

Important Operating, Maintenance and Safety Instructions

Carefully read all instructions before operating or servicing any Dynabrade® Abrasive Power Tool.

Warning: Hand, wrist and arm injury may result from repetitive work motion and overexposure to vibration.

Important: All Dynabrade Rotary Vane air tools must be used with a Filter-Regulator-Lubricator to maintain all warranties.

Operating Instructions:

Warning: Eye, face, respiratory, sound and body protection must be worn while operating power tools. Failure to do so may result in serious injury or death. Follow safety procedures posted in workplace.

1. With power source disconnected from tool, securely fasten abrasive/accessory on tool.
2. Install air fitting into inlet bushing of tool. **Important:** Secure inlet bushing of tool with a wrench before attempting to install the air fitting to avoid damaging valve body housing.
3. Connect power source to tool. Be careful not to depress throttle lever in the process.
4. Air tools are not intended for use in explosive atmospheres and are not insulated for contact with electrical power sources. Sanding/Grinding certain materials can create explosive dust. It is the employers responsibility to notify the user of acceptable dust levels. Sanding/Grinding can cause sparks which can cause fires or explosions. It is the users responsibility to make sure the work area is free of flammable materials.

Maintenance Instructions:

1. Check tool speed regularly with a tachometer. If tool is operating at a higher speed than the RPM marked on the tool, the tool should be serviced to correct the cause before use.
2. Some silencers on air tools may clog with use. Clean and replace as required.
3. All Dynabrade Rotary Vane air motors should be lubricated. Dynabrade recommends one drop of air lube per minute for each 10 SCFM (example: if the tool specifications state 40 SCFM, set the drip rate of your filter-lubricator at 4 drops per minute). Dynabrade Air Lube (P/N **95842**: 1 pt. 473 ml.) is recommended.
4. An Air Line Filter-Regulator-Lubricator must be used with this air tool to maintain all warranties. Dynabrade recommends the following: **11411** Air Line Filter-Regulator-Lubricator — Provides accurate air pressure regulation, two-stage filtration of water contaminants and micro-mist lubrication of pneumatic components. Operates 55 SCFM @ 100 PSIG has 1/2" NPT female ports.
5. Use only genuine Dynabrade replacement parts. To reorder replacement parts, specify the **Model #**, **Serial #**, and **RPM** of your machine.
6. A Motor Tune-Up Kit (P/N **96504**) is available which includes assorted parts to help maintain motor in peak operating condition. Please refer to Dynabrade's Preventative Maintenance Schedule for a guide to expectant life of component parts.
7. Mineral spirits are recommended when cleaning the tool and parts. Do not clean tool or parts with any solvents or oils containing acids, esters, ketones, chlorinated hydrocarbons or nitro carbons.
8. DO NOT clean or maintain air tools with chemicals that have a low flash point (example: WD-40®).

Safety Instructions:

Products offered by Dynabrade should not be converted or otherwise altered from original design without expressed written consent from Dynabrade, Inc.



- **Important:** User of tool is responsible for following accepted safety codes such as those published by the American National Standards Institute (ANSI).
- Always disconnect power supply before changing abrasive/accessory or making machine adjustments.
- Inspect abrasives/accessories for damage or defects prior to installation on tools.
- Please refer to Dynabrade's Warning/Safety Operating Instructions Tag (Reorder No. **95903**) for more complete safety information.

Notice

All Dynabrade motors use the highest quality parts and metals available and are machined to exacting tolerances. The failure of quality pneumatic motors can most often be traced to an unclean air supply or the lack of lubrication. Air pressure easily forces dirt or water contained in the air supply into motor bearings causing early failure. It often scores the cylinder walls and the rotor blades resulting in limited efficiency and power. Our warranty obligation is contingent upon proper use of our tools and cannot apply to equipment which has been subjected to misuse such as unclean air, wet air or a lack of lubrication during the use of this tool.

Full One Year Warranty

Following the reasonable assumption that any inherent defect which might prevail in a product will become apparent to the user within one year from the date of purchase, all equipment of our manufacture is warranted against defects in workmanship and materials under normal use and service. We shall repair or replace at our factory, any equipment or part thereof which shall, within one year after delivery to the original purchaser, indicate upon our examination to have been defective. Our obligation is contingent upon proper use of Dynabrade tools in accordance with factory recommendations, instructions and safety practices. It shall not apply to equipment which has been subject to misuse, negligence, accident or tampering in any way so as to affect its normal performance. Normally wearable parts such as bearings, contact wheels, rotor blades, etc., are not covered under this warranty.

Model Number	Motor HP (W)	Motor RPM	Sound Level	Maximum Air Flow CFM/SCFM (LPM)	Air Pressure PSIG (Bars)	Spindle Thread	Weight Pound (kg)	Length Inch (mm)	Height Inch (mm)
51370	1.3 (969)	12,000	85 dB(A)	8/50 (1,416)	90 (6.2)	3/8" -24	4.5 (2.0)	10-7/16 (265)	4-7/16 (112)
51371	1.3 (969)	12,000	85 dB(A)	8/50 (1,416)	90 (6.2)	5/8" -11	4.5 (2.0)	10-7/16 (265)	4-7/16 (112)
52620	1.3 (969)	12,000	85 dB(A)	8/50 (1,416)	90 (6.2)	5/8" -11	4.5 (2.0)	10-7/16 (265)	4-7/16 (112)
52625	1.3 (969)	12,000	85 dB(A)	8/50 (1,416)	90 (6.2)	M14 x 2	4.5 (2.0)	10-7/16 (265)	4-7/16 (112)

Additional Specifications: Air Inlet Thread 3/8" NPT • Hose I.D. Size 1/2" (13 mm)

Disassembly Instructions – 1.3 Hp Tools

Important: Manufacturer's warranty is void if tool is disassembled before warranty expires.

Notice: All of the special tooling referenced to in these instructions can be ordered from Dynabrade. See page 4 in manual.

Disconnect tool from the air supply before servicing.

Motor Disassembly:

1. Secure the **52609** Housing in a vise with aluminum or bronze jaws. Carefully hold the housing between the two handle bosses so that the motor spindle is pointing up.
2. Use the **96348** Adjustable Face Pin Spanner Wrench to remove the **54978** Lock Ring by turning it counterclockwise.
3. Remove the tool from the vise, and turn it over to allow the motor assembly to slide out of the housing.
4. Fasten the **96319** Bearing Separator (4") around the portion of the **54976** Cylinder that is closest to the **54977** Rear Bearing Plate.
5. Use parallel blocks under the bearing separator, positioning them on the table of the **96232** Arbor Press (#2). Place the bearing separator and motor assembly on the blocks so that the motor spindle is pointing down.
6. Use a 5/16" dia. drive punch as a press tool and push the rotor out of the **02651** Bearing.
7. Secure the body of the rotor in a vise with aluminum or bronze jaws so that the spindle is pointing up. Use a *heat gun* to heat the **54975** Rotor Nut and remove it with an adjustable wrench by turning it counterclockwise.
8. Remove the **54974** Front Bearing Plate, bearing, shims, and **52467** Rotor Spacer. **Note:** The motor bearings are a slip fit into the bearing plates.

Motor Disassembly Complete.

Valve Disassembly:

1. Place the **51989** Repair Collar around the air inlet end of the valve housing. Secure the collar and housing in a vise so that the **51937** Inlet Adapter is pointing up.
2. Warm the inlet adapter with a *heat gun* and remove it with an adjustable wrench by turning it counterclockwise.
3. Remove the valve components. **Note:** Use a hook shaped tool to remove the **51945** Seat.
4. Use the **96344** Pilot Punch (3/32" dia.) to remove the **96444** Roll Pin and the **51949** Safety Lock lever.
5. Push the **51946** Valve Stem Assembly out of the housing.

Valve Disassembly Complete.

Assembly Instructions – 1.3 Hp Tools

Important: Clean and inspect all parts before assembly. **Note:** Follow oil, adhesive, and torque specifications.

Motor Assembly:

1. Use a clean cloth to wipe the rotor, **54974** Front Bearing Plate, **52467** Rotor Spacer, and **02552** Bearing dry of any oil or grease film.
2. Slip the **52467** Rotor Spacer onto the rotor spindle making sure that it lays flat against the face of the rotor.
3. Select .003" (.08mm) thickness in shims from the **01277** Shim Pack and install these into the **54974** Front Bearing Plate.
4. Install the **02552** Bearing into the front bearing plate.
5. Install the front bearing/plate assembly onto the rotor spindle making sure that this assembly fits all the way down onto the rotor spindle.
6. Apply a small amount of the Loctite #609 (or equivalent) onto the rotor nut threads of the rotor.
7. Secure the body of the rotor in a vise with aluminum or bronze jaws so that the rotor spindle is pointing up and install the **54975** Rotor Nut. **Note:** Install the rotor nut so that the wrench flats are exposed toward the threads of the spindle. (Torque to 34 N•m/300 in lbs.)
8. Check the rotor/plate clearance with a .001" (0.03mm) feeler gage. The correct clearance should be .001"-.0015" (0.03 - 0.04mm). If the rotor/plate clearance needs adjustment, repeat shimming process adding or removing shims as required.
9. Once the correct rotor/plate clearance is achieved, install the **54972** Rotor Vanes (5/Pkg.) that have been lubricated with the **95842** Dynabrade Air Lube (10W/NR or equivalent).
10. Install the **54976** Cylinder so that the line-up pin will mate with the **54977** Rear Bearing Plate.
11. Install the **02651** Bearing into the **54977** Rear Bearing Plate.
12. Position the rotor nut on the **96231** Tool Plate of the arbor press. Use the **96239** Bearing Press Tool so that the raised center portion rest against the inner race of the **02651** Bearing. Press the bearing/plate assembly down onto the rotor until the **54977** Rear Bearing Plate touches the cylinder. This should create a snug fit between the bearing plates and the cylinder. A loose fit will not achieve the correct preload on the motor bearings.
13. Use a marking pen to mark the location of the motor line-up pinhole on the edge of the **52609** Housing. Also make a mark on the top of the **54974** Front Bearing Plate to show the position of the **51046** Pin. Sight the line-up marks and slide the motor assembly into the **52609** Housing making sure that the pin enters the pinhole that is located near the air supply inlet and exhaust ports of the housing.
14. Secure the **52609** Housing in a vise with aluminum or bronze jaws. Carefully hold the housing between the two handle bosses so that the motor opening is facing up.
15. Apply a small amount of the Loctite #567 (or equivalent) to the threads of the **54978** Lock Ring. Install the **54899** and/or **54889** Shim or a combination of these and the lock ring. (Torque to 34 N•m/300 in lbs.) **Note:** These shims are used to set the location of the shaft lock mechanism.
16. Install an approved accessory.

Motor Assembly Complete.

(continued on next page)

Motor Assembly/Disassembly Instructions – 1.3 Hp (continued)

Valve Assembly:

1. Apply a small amount of lubricant (oil or grease) to the **51946** Valve Stem Assembly O-Ring **96443** and install the o-ring end of the assembly into the valve housing. **Note:** If the **51946** Valve Stem Assembly is being reinstalled, replace the **96443** O-Ring.
2. Install the **51945** Valve Seat into the valve-housing inlet by aligning and inserting three prongs into the corresponding slots.
3. Install the **51944** Tip Valve so that the long portion fits under the end of the valve stem.
4. Place the smaller end of the **51943** Spring against the tip valve.
5. Install the **51939** Air Diffuser, **51940** Retainer, and **96442** O-Ring onto the **51937** Inlet Adapter.
6. Apply a small amount of the Loctite #567 (or equivalent) to the male threads of the inlet adapter and install these parts into the valve-housing inlet. Use the **51989** Repair Collar to hold the valve housing in a vise. Tighten the inlet adapter into the valve housing. (Torque to 34 N·m/300 in lbs.)
7. Reposition the valve housing and install the **51949** Safety Lock Lever securing it with the **96444** Roll Pin.

Valve Assembly Complete.

Throttle Lever Positioning Procedure:

1. Refer to the exploded view to identify the required parts and their order of assembly. Use only one or a combination of the **54803** Shim to position the throttle lever in a desired location.

Tool Assembly Complete.

Please allow 30 minutes for adhesives to cure before operating tool.

Important: Motor should now be tested for proper operation at 90 PSIG. If motor does not operate properly or operates at a higher RPM than marked on the tool, the tool should be serviced to correct the cause before use. Before operating, place 2-3 drops of Dynabrade Air Lube (P/N **95842**) directly into air inlet with throttle lever depressed. Operate tool for 30 seconds to determine if tool is operating properly and to allow lubricating oils to properly penetrate motor

Loctite® is a registered trademark of Loctite Corp.

Optional Accessories



96504 Motor Tune-Up Kit

- Includes assorted parts to help maintain and repair motor.



96232 (#2) Arbor Press

- This arbor press is ideal for the disassembly and assembly of air motors.



Dynaswivel®

Swivels 360° at two locations which allows an air hose to drop straight to the floor, no matter how the tool is held.

- **95461:** 3/8" NPT.



Dynabrade Air Lube

- Formulated for pneumatic equipment.
- Absorbs up to 10% of its weight in water.
- Prevents rust and formation of sludge.
- Keeps pneumatic tools operating longer with greater power and less down time.

95842: 1 pt. (473 ml)

95843: 1 gal. (3.8 L)



96319 Bearing Separator

- Use the separator to remove gears and bearings.



96348 Pin Spanner Wrench

- An adjustable 6mm pin wrench that can be used to remove motor lock rings and accessories.



96239 Bearing Press Tool

- This tool is designed to safely press a bearing into a bearing plate and onto a shaft.

Visit Our Web Site: www.dynabrade.com

Email: Customer.Service@Dynabrade.com



DYNABRADE, INC., 8989 Sheridan Drive • Clarence, NY 14031-1490 • Phone: (716) 631-0100 • Fax: 716-631-2073 • International Fax: 716-631-2524
DYNABRADE EUROPE S.à.r.l., Zone Artisanale • L-5485 Wormeldange—Haut, Luxembourg • Telephone: 352 76 84 94 1 • Fax: 352 76 84 95 1

©DYNABRADE, INC., 2005

PRINTED IN USA

Rev.01_PD03.22_05/05