



# Portable Vacuum System

## Parts List

**61315** (9.9 gal./36 ltr.) 120v-60Hz (US) - With Conductive Hoses



### “M” CLASS DRY VACUUM

When employed in accordance with their intended use, the industrial vacuum cleaners described in these operating instructions are suitable for picking up non-flammable, dry dusts. They correspond to dust class “M” in accordance to: EN 60335-2-69. By SLG, Germany

### 31962 COAXIAL VACUUM HOSE ASSEMBLY

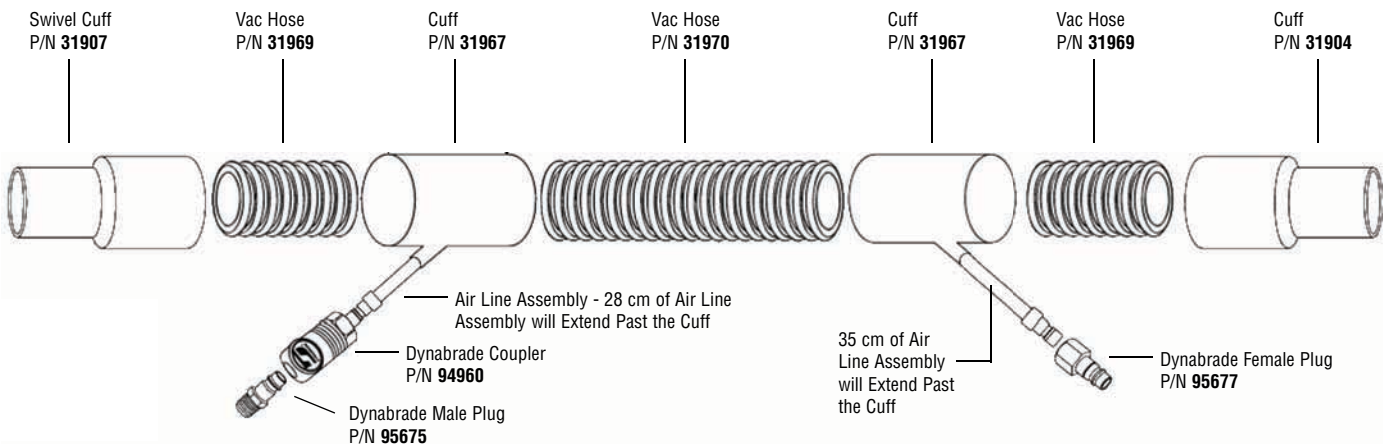

# MACHINE PARTS LIST – (9.9 gal./36 ltr.)

ITEM	PART NO.	DESCRIPTION
1	64684	H.E.P.A. Filter
	64683	(Optional) Paper Cartridge Filter
2	64685	Felt Insert
3	64682	Disposable Vacuum Bag (10/Pkg.)
4	80055	Side Hinge
5	80052	Rear Wheel Assembly
6	80050	Standard Front Wheel Assembly
7	80059	Motor (110/120 V - 60 Hz)
8	80077	Power Switch
9	80053	Vacuum Speed Control Assembly (110/120 V - 60 Hz)
10	80081	Handle Assembly
11	80085	Vacuum Inlet Assembly

## MOTORHEAD ASSEMBLY

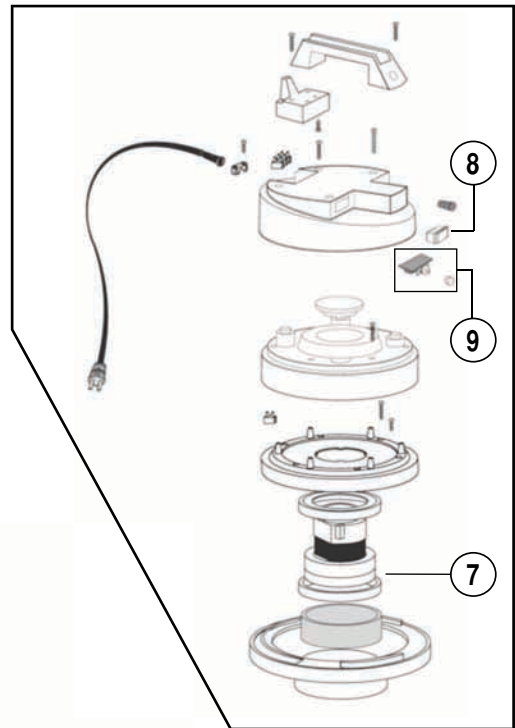

### Replacement Brushes:

80057 110/120 V - 60 Hz. (Qty. 2)

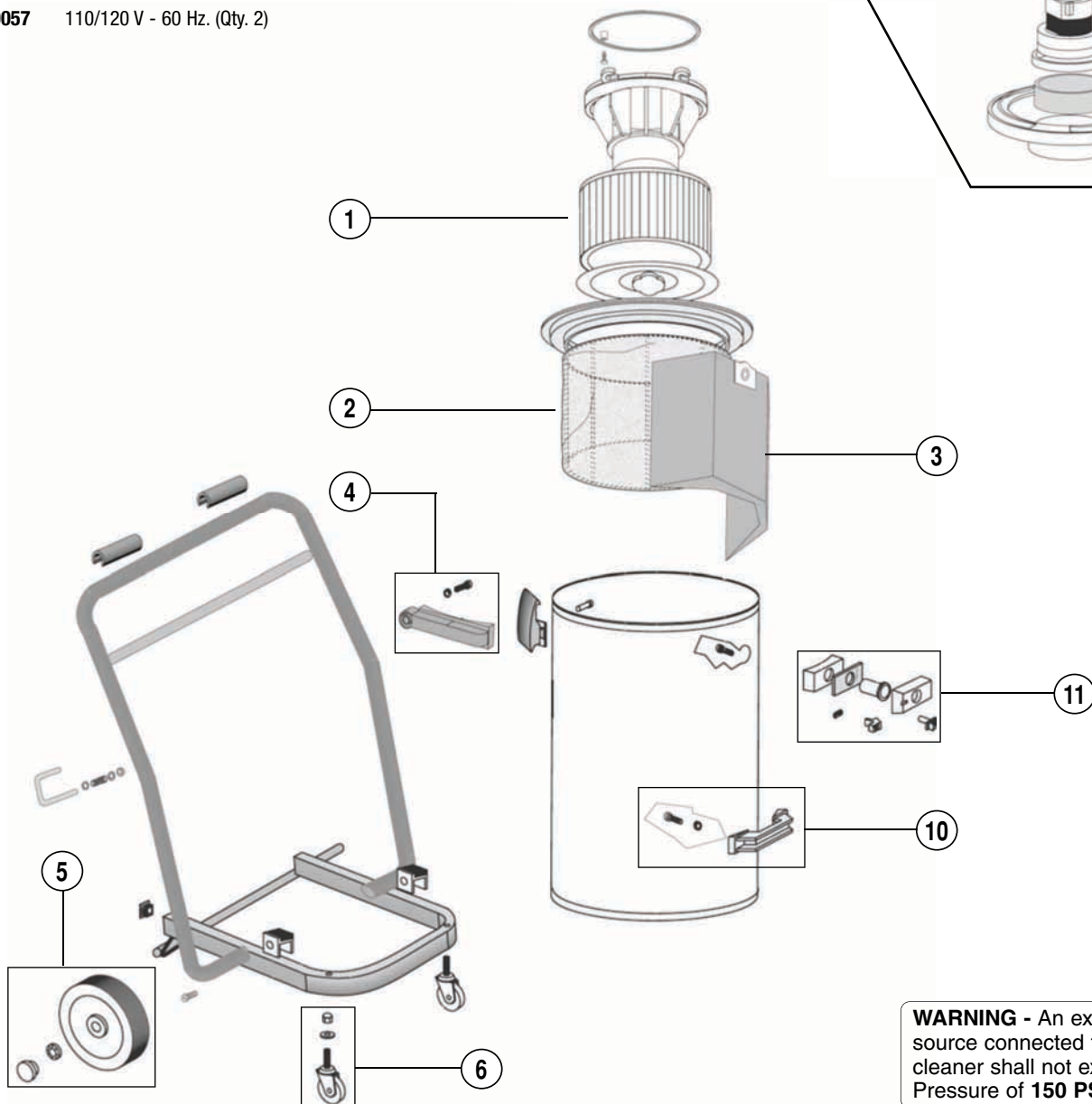

**WARNING** - An external air supply source connected to the vacuum cleaner shall not exceed the Max Pressure of 150 PSI.

## OPTIONAL ACCESSORIES



### Replacement Brushes

- 80057** 110 V - 60 Hz. (Qty. 2)
- 80058** 230 V - 50 Hz. (Qty. 2)
- 80082** 220 V - 60 Hz. (Qty. 2)



### 80051 Locking Front Wheel Assembly

- Allows to lock the entire unit with the simple ease of a push-lock system.



### Disposable Vacuum Paper Bag

- A minimum order quantity of 10.

- 64682** (9.9 gal./36 ltr.) 10/Pkg.
- 80076** (17 gal./64 ltr.) 10/Pkg.



### 31968 "Y" Vacuum Connector

- Allows for two tools to be connected to the same Portable Vacuum System.



### 61361 Vacuum Edge Guard

- Non-Marring protective edge allows vacuum unit to be placed on finished surfaces.

**Note:** For use with 9.9 gal./36 ltr. models only.



### 96558 Vacuum Cleaning Kit

(Includes The Following)

- Hose
- Extension Pipe (2)
- Curved Handle

(Includes The Following Attachments)

- Round Brush
- Coarse Dirt Nozzle
- Crevis Tool

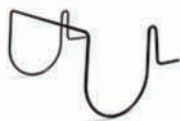

### 96581 Vacuum Tray Hose Hanger

- Easily installed onto Vacuum Tray. (Requires Vacuum Tray To Install.)



### 96534 Wall Mount Bracket

- Keep vacuum off floor and convenient for use.

**Note:** For use with 9.9 gal./36 ltr. models only.



Dynabrade Offers A Complete Line of Hose Cuffs and Reducers. Refer To Dynabrade's Current Catalog



### Vacuum Filters

- Easily installed, keep filters clean to ensure proper suction.

**64684** H.E.P.A. Filter

**64683** Standard Filter



### Vacuum Tray

- A convenient storage shelf to place work related items.

**96567** (9.9 gal./36 ltr.)

**96563** (17 gal./64 ltr.)

## DYNABRADE CUSTOMER SERVICE

US Consumers Call Toll-Free: 1-800-828-7333 • Canadian Consumers Call Toll-Free: 1-800-344-1488

### DYNABRADE, INC.

8989 Sheridan Drive • Clarence, New York 14031-1490 • Phone: (716) 631-0100  
Fax: 716-631-2073 • US Consumers Call Toll Free: 1-800-828-7333

### DYNABRADE INTERNATIONAL

8989 Sheridan Drive • Clarence, New York 14031-1490 • Phone: (716) 631-0100  
Fax: 716-631-2524 • Canadian Consumers Call Toll Free: 1-800-344-1488

### DYNABRADE EUROPE S.à r.l.

Zone Artisanale • L-5485 Wormeldange-Haut, Luxembourg  
Phone: +352 768 494 1 • Fax: +352 768 495

### DYNABRADE DO BRASIL

Rua Mário Fongaro • 421 - Vila Marlene • São Bernardo do Campo  
SP - CEP 09732-530 • Telefax: (11) 4124-6040

[www.dynabrade.com](http://www.dynabrade.com)

